



## Viomi Alpha 2 Pro User Manual

Please read this manual carefully before use and keep it properly.  
This product shall be operated only in location at altitude below 2,000 meters.

# CONTENTS

Safety Information .....	01
Packing list .....	04
Product Introduction .....	05
Instructions on Installation .....	07
Operation Instructions .....	07
How to connect to Wi-Fi .....	09
Maintenance .....	10
Specifications .....	14
Trouble Shooting .....	15
FAQ .....	15

# 1. Instructions for use

Please pay attention to the following basic safety precautions before using the product:

- Read the user manual carefully and follow the instructions in the user manual when using the product.
- Keep the user manual well for future reference.
- If you need to transfer the product to a third party, please attach the user manual along with the product.
- Any operation not in conformity to the instructions in the user manual may result in serious personal injury or damage to the product itself.

 Warning: Instructions against incorrect product use that may lead to death or serious injury.

 Caution: Instructions against incorrect product use that may lead to minor injury or product damage.

 Read operator's manual

# 2. Safety precautions

 Warning

- This product can only use the automatic dirt disposal and batteries that are provided with this product. Failure to do so may result in damage to the product, electrical shock, or fire caused by high voltage.
- Do not use this product if the product and accessories of this product are found to be damaged. Contact our after-sales service department. Except for the service technicians designated or authorized by our company, no one may disassemble, repair or modify this product.
- Unplug the product before maintenance.
- Do not touch the power plug or the product when your hands are wet, as this may result in electrical shock.
- If the power cord is damaged, it must be replaced by the manufacturer, its service department or a similar professional to avoid danger.

- To prevent the product from falling accidentally, do not use this product in a suspended place without a protective fence, which may result in personal injury.
- The user shall not replace the batteries privately.
- Prevent clothing or any part of your body (hair, fingers, etc.) from getting caught in the brush or wheel of the vacuum cleaner. Failure to do so may result in personal injury.
- Do not place the product near fire or flammable/explosive/corrosive materials.
- If the user manual is missing, please contact your local dealer or call the after-sales service department to obtain an electronic user manual.
- If the supply cord is damaged, it must be replaced by the manufacturer, its service agent or similarly qualified persons in order to avoid a hazard.

 Caution

- This appliance contains batteries that are only replaceable by skilled persons.
- For the purposes of recharging the battery, only use with the automatic dirt disposal provided with this appliance.
- Check whether there are cigarette butts, matches and other inflammable and explosive items in the room. If there is one will need to manually clean up yourself before use of the product. Flammable items inhaled robot, the body in the use of the process will heat damage product.
- Clean edge brushes and rollers regularly, clean the dust box regularly, clean the filter regularly.
- The appliance must be disconnected from the supply mains when removing the battery.
- The battery is to be disposed of safely.
- The product is only intended to clean floors in a home environment. Please do not use it outdoors such as on an open balcony or on a surface that is not a floor like a sofa, or in a commercial or industrial setting.

## Safety Information

- Prevent the suction of water, oil or other liquids, which may damage the product.
- Please make sufficient preparations before starting the product to prevent the noise from causing harm to people or animals.
- Arrange scattered wires on the floor before use for fear of affecting the normal operation of the product.
- Remove fragile objects before use.
- The charging dock shall be placed against the wall and on a flat floor for fear of affecting product functionality.
- Unplug the automatic dirt disposal if it remains unused for a long time.
- When the product is working, removal of the automatic dirt disposal will affect the normal recharging of the machine.
- Do not use the product to suck in sharp objects (e.g. shattered glass and nails) for fear of damage to the product.
- Do not use the product at an ambient temperature above 40°C or below 0°C or in a wet, flammable, explosive or corrosive environment.
- Do not charge at an ambient temperature above 35°C or below 0°C.
- Do not pick up the product by its laser radar cover.
- Make sure the product is turned off and the automatic dirt disposal is unplugged before cleaning or performing maintenance.
- Do not place children, pets, or any item on top of the product while it is stationary or moving.
- Do not spray any liquid into the product (make sure the dust compartment is thoroughly dry before its reinstalling).
- Do not place the product upside down (laser radar housing should never touch the ground).
- Only use this product as directed in the user manual or quick start guide. Users are responsible for any loss or damage arising from improper use of this product.

### 3. About child safety



- Children shall not play with the product.
- Please keep the main brush cleaning tools out of reach of children.

- This product can be used by children aged from 8 years and above and persons with reduced physical, sensory or mental capabilities or lack of experience and knowledge if they have been given supervision or instruction concerning use of the appliance in a safe way and understand the hazards involved.
- Cleaning and user maintenance shall not be made by children without supervision.

### 4. About the batteries



- This product contains a lithium-ion battery pack.
- Do not expose the appliance or battery to excessive temperatures.
- Be aware of the risk of terminals of the battery-operated appliance or battery being short-circuited by metal objects.
- Before disposing of the appliance, the battery must be taken out of the appliance. Take-out steps:
  - A. Take off the side brush. Use a screwdriver to loosen the screws of and the base decorative plate.
  - B. Remove the base trim panel.
  - C. Take out the battery and unplug the connection line between the battery and the host.
- The batteries shall be removed when the product is discarded.
- If you need to replace the battery of the host machine, please contact our after-sales service department. Use of wrong batteries may cause a safety accident.
- If the batteries leak, prevent the contact of the liquid with the skin or clothing. Immediately wipe it with a dry cloth and send it to the recycling station or designated maintenance point. Do not discard it.
- Please properly dispose of the old batteries of the product. The batteries contain hazardous substances harmful to the environment. Please follow the local environmental regulations and send them to the designated recycling site.

### 5. Scope of use of the product

The product is suitable for the following floors:  
Wooden floor, Ceramic tile and Short-staple carpet.

### 6. Disclaimers

Under any of the following circumstances, the product will be excluded from the scope of free warranty, but paid repair can be provided:

- A. Damage due to the user's failure to operate the product in strict accordance with our user manual or due to improper storage;
- B. The machine or parts have exceeded the free warranty period;
- C. Damage due to disassembly by those other than the maintenance personnel of our company or authorized by our company;
- D. A valid purchase voucher number cannot be provided;
- E. Damage caused by irresistible factors such as natural disasters;
- F. Product failure or damage caused by unexpected factors or man-made causes (including operational errors, liquid ingress, improper plugging/unplugging, scratching, handling, bumping, input of inappropriate voltage, etc.)

## Packing list

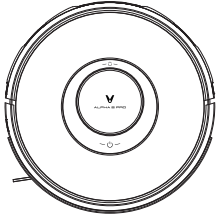

Robot vacuum-mop x 1

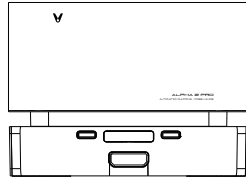

Automatic dirt disposal x 1

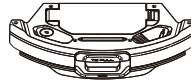

2-in-1 water tank x 1



Main brush x 1



Side brush x 1



HEPA filter x 1

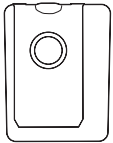

Dust bag x 3

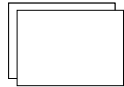

Handbook x 1  
Quick Guide Manual x 1

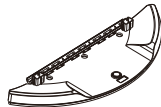

Mop holder x 1



Mop x 2



Disposable mop x 10



Cleaning tool x 1



Main brush  
cover x 1



HEPA for automatic  
dirt disposal x 1

### Notes:

HEPA filter and cleaning tool are installed on the 2-in-1 water tank.



2-in-1 water tank, main brush and side brush is installed on the robot.



Dust bags and HEPA is installed on the automatic dirt disposal or accessories box.

Mop is installed on the mop holder.

# Product Introduction

## Network Configuration

When the robot is power-on, simultaneously press down and hold  and  keys for 3 seconds till a voice prompt "Activate network configuration" is given, and then release them to activate network configuration.

When the robot is power-on, simultaneously press down and hold  and  keys for 10 seconds till a voice prompt "Robot is going to restore factory settings" is given, and keep holding the keys for 10 seconds till a voice prompt "Robot has restored factory settings successfully" is given. A reboot is needed after the restoration.

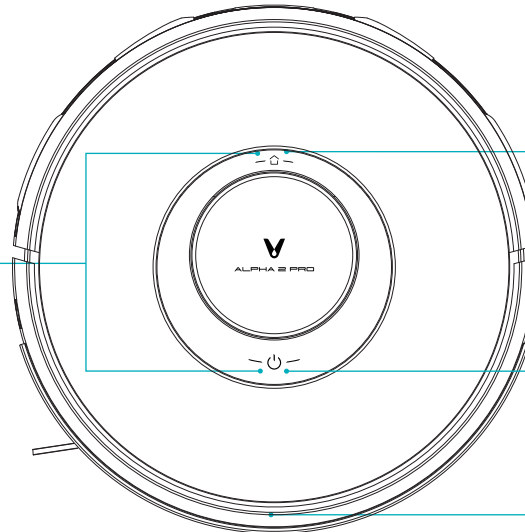

## Smart recharging

- Short press the button to start smart recharging.
- Long press for 5 seconds to enable pair mode

## Power on/off, Global cleaning

- Short press the button to start/pause cleaning
  - Long press the button for 3 seconds to power on/off
- White glimmers: robot standby  
White: working/pause/full battery  
Slowly blinking white: network connecting  
Blinking orange: recharging/charging/disposing dirt  
Slowly blinking orange: low battery/malfunction  
The LED indicator off: indicating power-off/sleep

## IR sensor

## Reset button: for forcible shutdown.

- Short press to switch off

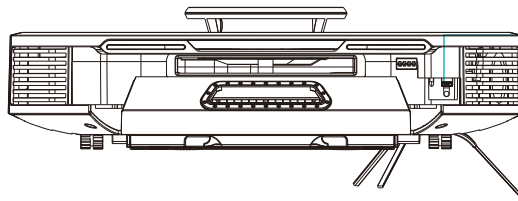

# Product Introduction

## Robot Vacuum-mop and sensor

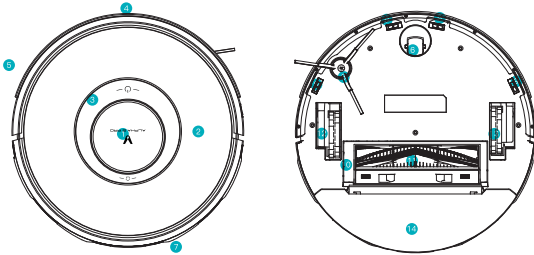

- ① Laser radar
- ② Surface cover
- ③ Button
- ④ IR sensor
- ⑤ Collision sensor
- ⑥ Universal caster
- ⑦ Charging electrode
- ⑧ Side brush
- ⑨ Cliff sensor
- ⑩ Main brush cover
- ⑪ Rolling brush
- ⑫ Left caster
- ⑬ Right caster
- ⑭ 2-in-1 water tank

## 2-in-1 Water Tank

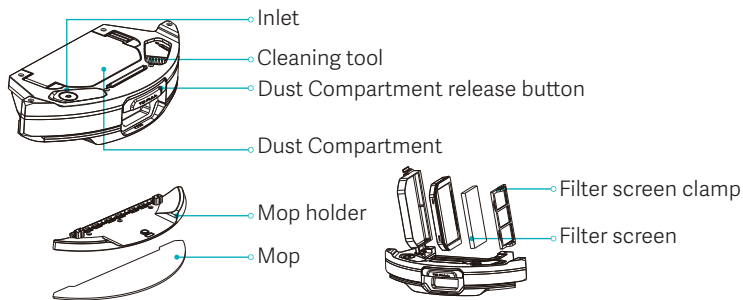

## Automatic dirt disposal (Two-in-one for dust collection and charging)

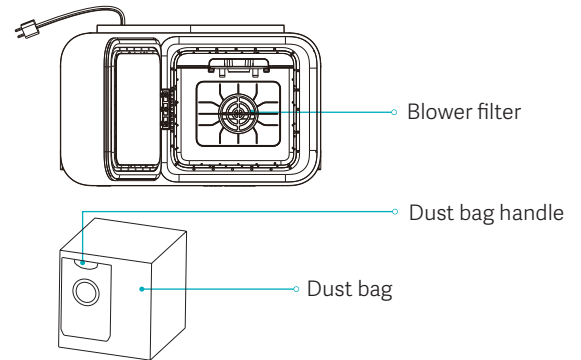
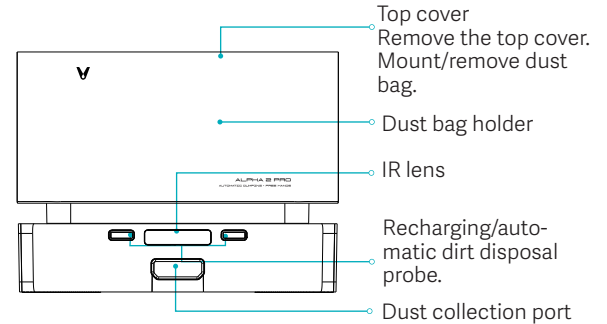

Dust bag (include a automatic dirt disposal).  
 Note: Bust bag is consumable and shall not be re-used.  
 Replace it regularly.



## Instructions on Installation

### Install the automatic dirt disposal

(1) Place automatic dirt disposal on flat floor near wall, and connect the plug to a approved socket and switch power supply on.

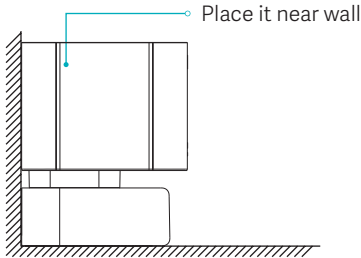

(2) Make sure there is no obstacle within 1.2 m in front and 0.5 m at both sides of it.

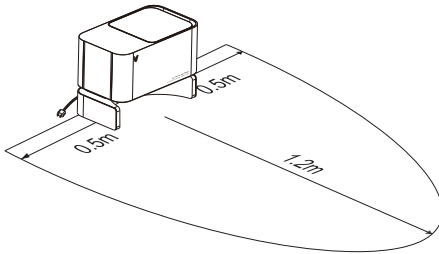

## Operation Instructions

### Switch on/off

Long press power button  $\text{⏻}$  for 3 seconds to switch robot on.

Power LED indicator flashes slowly and then lights on constantly in white color, and the robot in standby.

When robot stays still, long press the power button  $\text{⏻}$  for 3 seconds to switch it off.

Robot will sleep if being idle for more than 10 minutes. In sleep status shorting press any button will wake it up.

Tips: During recharging, the robot cannot be switched off or sleep.

### Sweeping

In power-on status, short press the  $\text{⏻}$  button with voice prompt "start global sweeping".

During cleaning, short press the  $\text{⏻}$  button to pause cleaning.

Tips: At low battery level, cleaning function cannot be started.

### Automatic/manual recharging

Upon end of cleaning, a voice prompt "cleaning finished and recharging started" is given, and the robot starts recharging.

In case of low battery level during cleaning, the robot will start recharging automatically.

### Refilling tank or cleaning mop half-way

Short press  $\text{⏻}$  button to pause the robot; remove mopping module, refill the tank or clean the mop; re-mount the mopping module and short press the button again to resume cleaning.

## Operation Instructions

### Network configuration and firmware update

Download Mijia App, and use the mobile client to reset Wi-Fi according to the APP's tips. Refer to the Quick Guide for further information. You can check and upgrade firmware through the App. Make sure the equipment is charging while upgrade. Read the guide in the App for the details of upgrade. Configure network according to the tips in the App after finishing download. You can use the App for remote control, reservation and so on as long as it is connected to network.

### Fault

In case of fault in the robot, audible and visual alarms will be given with power LED indicator flashing in orange. For more details refer to Troubleshooting.

The robot will sleep automatically when being idle for 10 minutes in case of fault.

### How to use

1. Place the robot on flat floor indoors. Remove the limit protector at both sides of bumper.

2. Press the Dust Compartment release button to remove the 2-in-1 Dust Compartment with Water Tank.

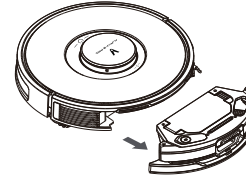

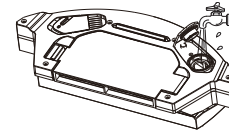

3. Soak the mop with water and attach it to magic tape band and tighten it. Inject water through the inlet, and tighten the cover.

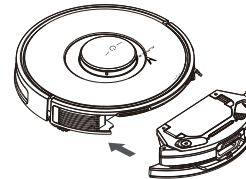

4. Mount the 2-in-1 Dust Compartment with Water Tank into the robot. To install the Integrated tank back, push it in with the slot. Then push it to the bottom after hearing a click.



## Operation Instructions

5. Long press button  for 3 seconds to switch the robot on, and then short press button  to recharge it. The robot will be ready for operation when recharged fully.

6. The robot will return to automatic dirt disposal base after operating for more than 1 minute, and start clear-up process automatically. The automatic dirt disposal function can be turned on or off via the APP settings. After the automatic dirt disposal function is turned off, the automatic dirt disposal will not be performed when robot returns to the automatic dirt disposal base.

Note:

1. The robot cannot be switched on in case of low battery level. In such case, first recharge it.
2. In case of low battery level during sweeping, the robot will go to charging dock for recharging automatically, and then return to the interruption point to resume cleaning.
3. For the initial use, there may be a very little water in the tank, which is residual test sample and at normal condition, and you can use it at ease.
4. Before performing cleaning, please make sure the 2-in-1 dust compartment with water tank has been well installed on the robot as well as the filter screen and filter screen clamp of the 2-in-1 dust compartment with water tank have been installed.
5. Please close the top cover of the automatic dirt disposal before dirt disposal is performed.
6. Please check whether dust duct is blocked and remove any foreign matter if the dirt disposal process is abnormal.

## How to connect to Wi-Fi

### Connect to Mijia App

This product works with Mijia app. Control your device, and interact it and other smart home devices with Mijia app.

Notes: As Mijia App is subject to improvement and update from time to time, the actual operations may vary from what is described above. Please perform your operations by following the instructions in current Mijia App.

Attention: "works with Mijia" validates in software level only. MIUI and Mijia is not responsible for the enterprise and its production, standard implementation, quality supervision and other aspects of the product.



Scan the QR code to download and install the app. You will be directed to the connection setup page if the app is installed already. Or search "Viomi mall/Mijia" in the app Store to download and install it. Open the app, tap "+" on the upper right, and then follow prompts to add your device.



## How to connect to Wi-Fi

### Connect power supply

Connect power plug to the socket.

### Download the App

Search for "Viomi mall" or "Mijia" in app store; or scan the QR code to download and install the app.

### Bind Android-based cell phone to Wi-Fi



Tap the available product, and tap "connect" to proceed. Just follow the tips.

### Bind iOS-based cell phone to Wi-Fi

Select robot's hotspot in Wi-Fi settings of your phone, and wait for connection; Return to the App, tap "next" and follow the tips to finish connection.

Notes: Please refer to How to Reset Wi-Fi when your phone is unable to connect Viomi vacuum (as following); Please connect to Wi-Fi for optimal user experience.

### Resetting Wi-Fi

When your router is replaced or Wi-Fi password is changed, you have to reset Wi-Fi settings by holding both  and  keys for 3 seconds till the Wi-Fi indicator light flashes in white color and a voice prompt is given, indicating that the Wi-Fi settings are reset successfully.

## Maintenance

### 2-in-1 Dust Compartment with Water Tank

1. Press Dust Compartment release button and pull the tank out to remove it.

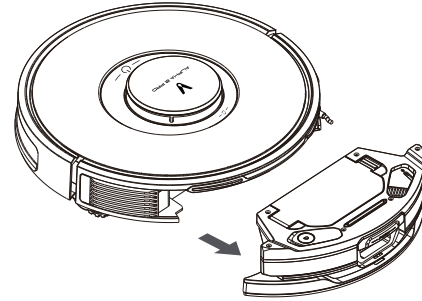

2. Release the Dust Compartment clamp to remove filter screen clamp.

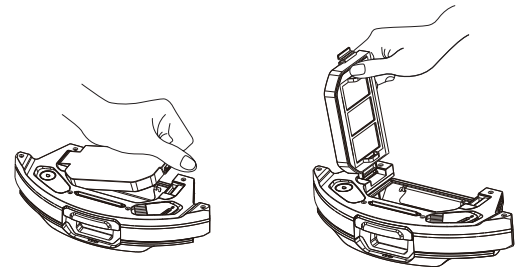

## Maintenance

3. Remove the Filter screen.

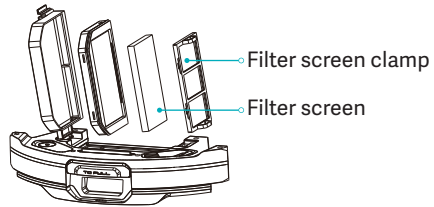

4. Clean the filter screen and clamp with cleaning brush.



5. Fill the Dust Compartment with water, shake it and then empty it. Repeat this process till it is clean.

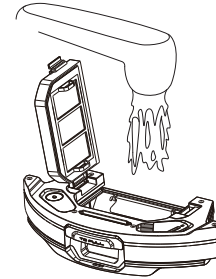

6. Turn the tank over and remove mop for cleaning or replace it.

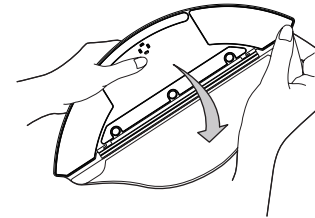

### Tips:

1. Clean the mop regularly, since contaminated mop will impair sweeping performance.
2. Be sure to remove the mop and clean, and then dry it by twisting. Do not clean it with it mounted to tank, which may cause damage to the tank.
3. It is recommended to replace main brush every 1-2 months to ensure proper cleaning performance.

## Maintenance

### Cleaning main brush

1. The main brush is consumable and shall be cleaned weekly. It is recommended to replace main brush every 6-12 months to ensure proper cleaning performance. Turn cleaner over, remove main brush cover and the brush by pressing the clamp on the cover.  
Note: Avoid collision when turning it over to avoid damage to laser radar.

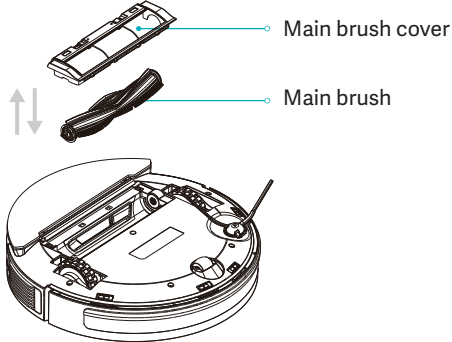

2. Cut off hairs around the brush with knife, and clean the main brush with the other end of the knife.

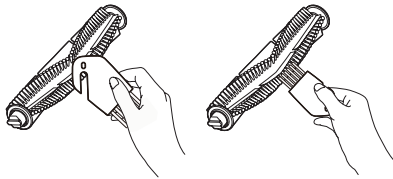

3. Mount the main brush and main brush cover and lock the clamp.

### Clean/replace side brush

1. The side brush is connected by buckles, and can be removed by hands easily.

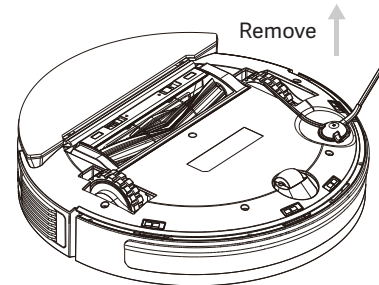

2. Mount side brush after cleaning, or replace the side brush.

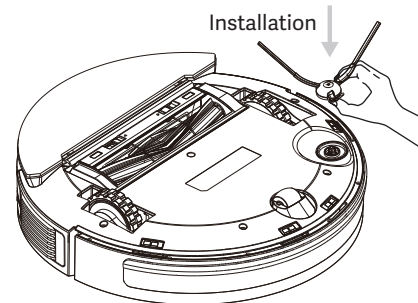

Tips: It is recommended to replace side brush every 3-6 months to ensure proper cleaning performance.

## Maintenance

### Replace dust bag

1. When the dust bag is full, the orange LED indicator on dirt disposal will lighting. Please change for a new one.". Please change dust bag in time when it's full to keep dirt disposal function normal.

### Replace dust duct

1. Invert the dirt disposal to check whether the dirt tunnel is blocked by foreign matter. If it is blocked, use screwdriver to detach the transparency cover and remove the foreign matter according to the following picture.

Note: Do not dismantle it with excessive force.

After finishing clear-up, mount it again in place.

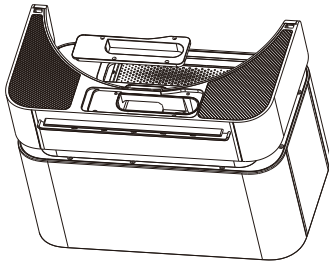

### Clean sensor

1. It is recommended to weekly clean each sensor with clean and soft cloth to ensure proper cleaning performance.

Robot vacuum-mop:

Cliff sensor×4

Charging electrode×2

Laser sensor×3

Laser radar×1

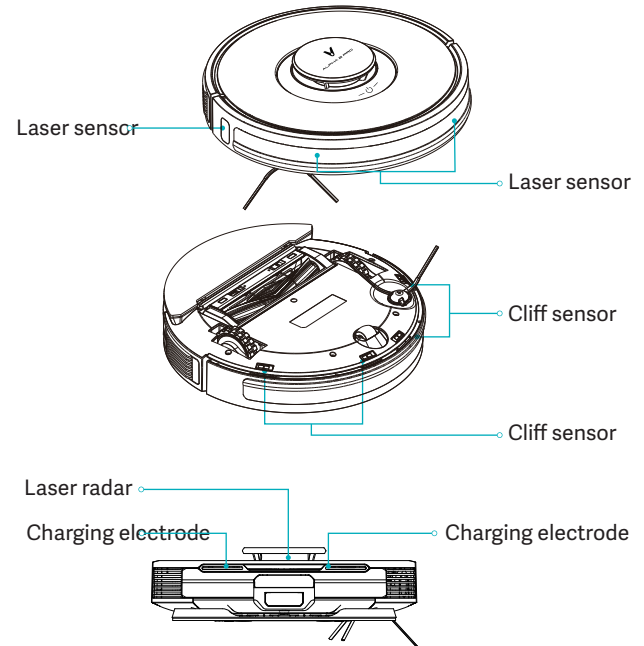

## Maintenance

Automatic dirt disposal charging dock:

IR lens×1

Automatic dirt disposal charging probe×2

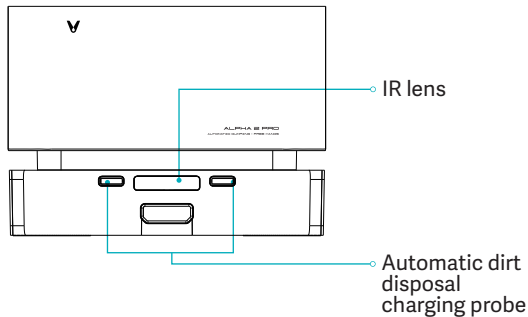

### Maintenance of battery

1. The robot is equipped with a high-performance rechargeable lithium-ion battery pack. Please keep the battery charged regularly to maintain its performance.
2. If you do not use it for a long time, please turn it off, and charge it at least once a month to avoid damage to the battery due to over-discharge.

## Specifications

### Robot Vacuum-mop

Model	V-RVCLMD40B
Dimensions	φ 350mm×95mm
Rated voltage	14.4V ===
Rate power	55W
Battery capacity	5200mAh
Wireless Connectivity	Wi-Fi IEEE 802.11b/g/n 2.4GHz
Operation Frequency	2400-2835MHz
Maximum Output Powers	≤18 dBm

### Automatic dirt disposal

Model	V-RVCLMD40B
Rated power	1050W
Rated input	220 - 240V~
Rated output	24V===1.5A
Rated frequency	50-60Hz
Dimensions	405*238*295mm

This product is in compliance with Class I laser safety standard under IEC60825-1:2014, and will not generate laser radiation hazardous to human.



## Trouble Shooting

Fault Prompt	Solution
Error #1. Make sure the laser ranging sensor is not blocked.	Check for or remove any foreign matter around laser radar, or relocate the robot and restart it.
Error #2. Clean cliff sensor and relocate the robot.	Clean the cliff sensor and try again (for more details refer to the user manual).
Error #3. A strong magnetic field is detected. Relocate the robot and try again.	Relocate the robot and try again.
Error #4. Check collision sensor and remove any foreign object on it.	Try to press the bumper strip and remove any foreign matter, and then restart the robot.
Error#5. The robot is at abnormal temperature. Stop operating till normal temperature is recovered.	The robot is in too high or low temperature. Stop operating till normal temperature is recovered.
Error #6.Charging fails. Please clean charging contact	Check the adapter, or check whether the automatic dirt disposal is at horizontal position. Switch off the robot and the automatic dirt disposal, clean their metal contacts.

## FAQ

Problem	Solution
Fails to start up	Low battery. Please go to dirt disposal for recharging before use. Ambient temperature too low (lower than 0°C) or too high (higher than 50°C)
Fails to start sweeping	Low battery. Please go to dirt disposal for recharging before use
Fails to recharge	There are too many obstacles near the dirt disposal. Please put the dirt disposal in an open area. Main machine is too far from the automatic dirt disposal. Please put it near the automatic dirt disposal and try again.
The machine operates improperly.	Power it off and than power it on again.
Cleaning operation is noisy.	Main brush, side brush or left/right caster is damaged by foreign object Power off the machine and remove the foreign object
Cleaning performance deteriorates or dust drops.	The automatic dirt disposal is full of dust. Please empty the collector. Filter component is blocked. Please clean it Main brush is damaged by any foreign object. Please clean the main brush.
Wi-Fi connection is unavailable.	Weak Wi-Fi signals. Make sure the robot is in proper coverage of Wi-Fi signals. Wi-Fi connection fails. Reset Wi-Fi connection and download the latest App and try again.
Robot is always offline.	Make sure the machine is connected to network successfully, and always within coverage of Wi-Fi.

## FAQ

Problem	Solution
Breakpoint resume.	Make sure non-disturbance mode is not activated, which will disable proceeding at breakout point Proceeding at breakout point is unavailable when the machine is being charged.
Robot fails to return to charging dock after fixed point cleaning or being repositioned.	As the robot will re-generate a map after fixed-point cleaning or being repositioned by a long distance, it may fail to locate charging dock for charging. In such case, place the machine onto charging dock manually.
Charging fails.	Make sure there is sufficient spaces around charging dock, and there is no dust or blockage on the surface of electrode of charging dock.
Scheduled cleaning fails.	Make sure the machine has been connected to the network, as disconnection from network will fail sync and scheduled cleaning task.
Robot fails to be paired with cell phone.	Make sure both charging dock and main machine are within coverage of Wi-Fi and good signals, and then reset Wi-Fi connection for pairing by following the instructions in the manual.





**VIOMI**  
[www.viomi.com](http://www.viomi.com)

Manufactured by: Guangdong Lizi Technology Co., Ltd

Address: Room 1-6, North of 1st Floor, Block A, Shengda Industrial Park, North No.2, Xinxu Four Road, Xiashi Village, Lunjiao Town, Shunde District, Foshan, Guangdong, China

RoHS

CE

